

# UHC Auxiliary External Power Cord Kit

826-2885

Follow these instructions to install an additional power cord on a UHC, UHC-P, UHC-HD or UHCTHD cabinet, which will be connected to an external auxiliary power supply that exclusively powers the control circuits.

1. Remove power from unit.
2. Remove sides by removing two screws at the base of each side.
3. Remove top by removing screws securing top to the cabinet.
4. Remove the plug in the side of the cabinet opposite the existing power cord and route the new cord with strain relief into the cabinet.
5. Follow the wiring diagrams on the included pages to install the provided wire:
  - UHCTHD, page 2
  - UHC-HD, page 3
  - UHC-P, page 4
  - UHC, page 5
6. Return the unit to position and test.

**NOTE:** Out-the-back wire routing is available for UHC-HD/UHCTHD cabinets.



**UHCTHD**



**UHC-HD**



**UHC-P**



**UHC**



**Figure 1:** All units except UHCTHD are disassembled in a similar fashion. Two screws, at the base of each side, secure the side panels. UHCTHD have four screws on the top of the cabinet.

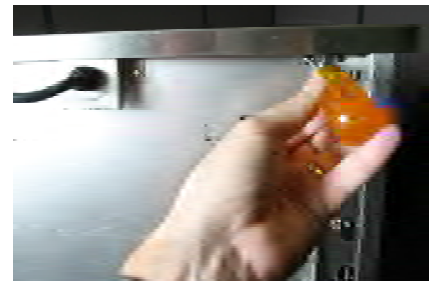

**Figure 2:** The top is secured with tabs, which extend down and are captured by screws just under the lid.

IN KIT 826-2885		
PART #	DESCRIPTION	QTY
8051869	UHC-HD DIAGRAM	1
8051515	UHC-P DIAGRAM	1
8051342	UHC DIAGRAM	1
8076612	HARNESS	1
8070263	TERMINAL .250 BUTTERFLY SPADE	2
8075250	CORDSET	1
*	WIRES	2
2307360	CORDSET HANGER	1
8196565	CORDSET HANGER INST	1
8140045	TYWRAP	2
8196761	INSTRUCTIONS	1

\* W1C602 to replace 1C on UHC; W63C517 to replace 63C on UHC.

# UHCTHD

- Step 1 - Remove power from the unit.
  - Step 2 - Remove the 4 screws attaching the top of the unit.
- Follow additional steps below and to the right.

Step 6 - Connect the new power harness (8076612) with black and white wires to the power supply.

Step 7 - Disconnect the connectors from terminals 0 & 1 on the relay.

Step 8 - Connect the included butterfly connectors to terminals 0 & 1 of the relay.

Step 9 - Connect the connectors removed in step 7 to the butterfly connectors on terminals 0 & 1 of the relay.

Step 10 - Connect the spade terminals from the new power supply harness (8076612) to the butterfly connectors on terminals 0 & 1 of the relay.

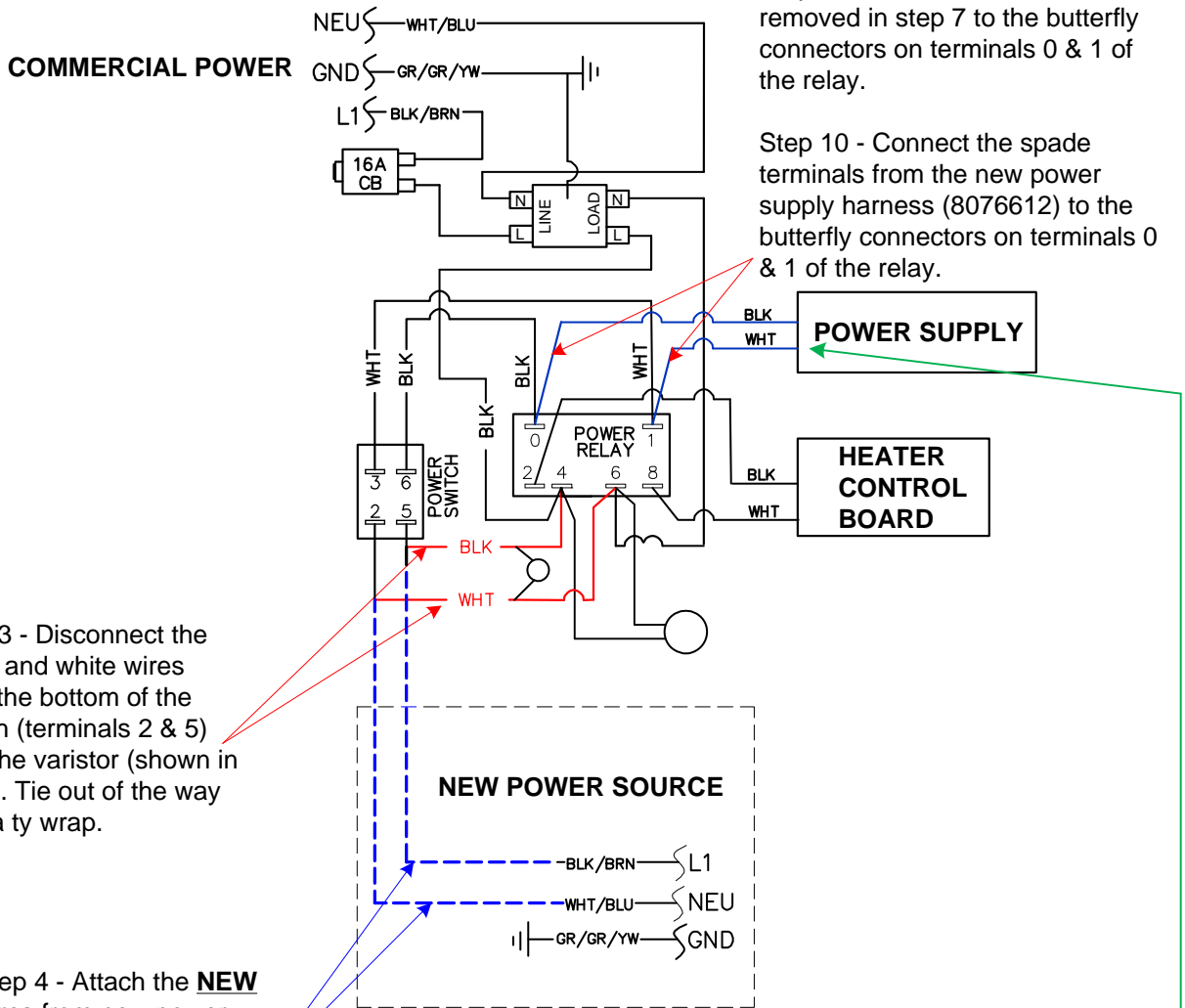

Step 3 - Disconnect the black and white wires from the bottom of the switch (terminals 2 & 5) with the varistor (shown in RED). Tie out of the way with a ty wrap.

Step 4 - Attach the **NEW** wires from new power source (shown in BLUE) to terminals 2 and 5 on the bottom of switch. L1 to terminal 5, Neutral to terminal 2.

Step 5 - Disconnect the existing harness with black and white wires from the power supply (see GREEN arrow). Tie out of the way with a ty wrap.

# UHC-HD

1. Follow directions on Page 1 to access unit component shelf.
2. Remove Black and White wires which connect the power relay to the power switch.
3. Move the varistor from the switch to the relay.
4. Attach the **NEW** power cord for external power supply to terminals 2 and 5 of the power switch, L1 to terminal 5, Neutral to terminal 2.

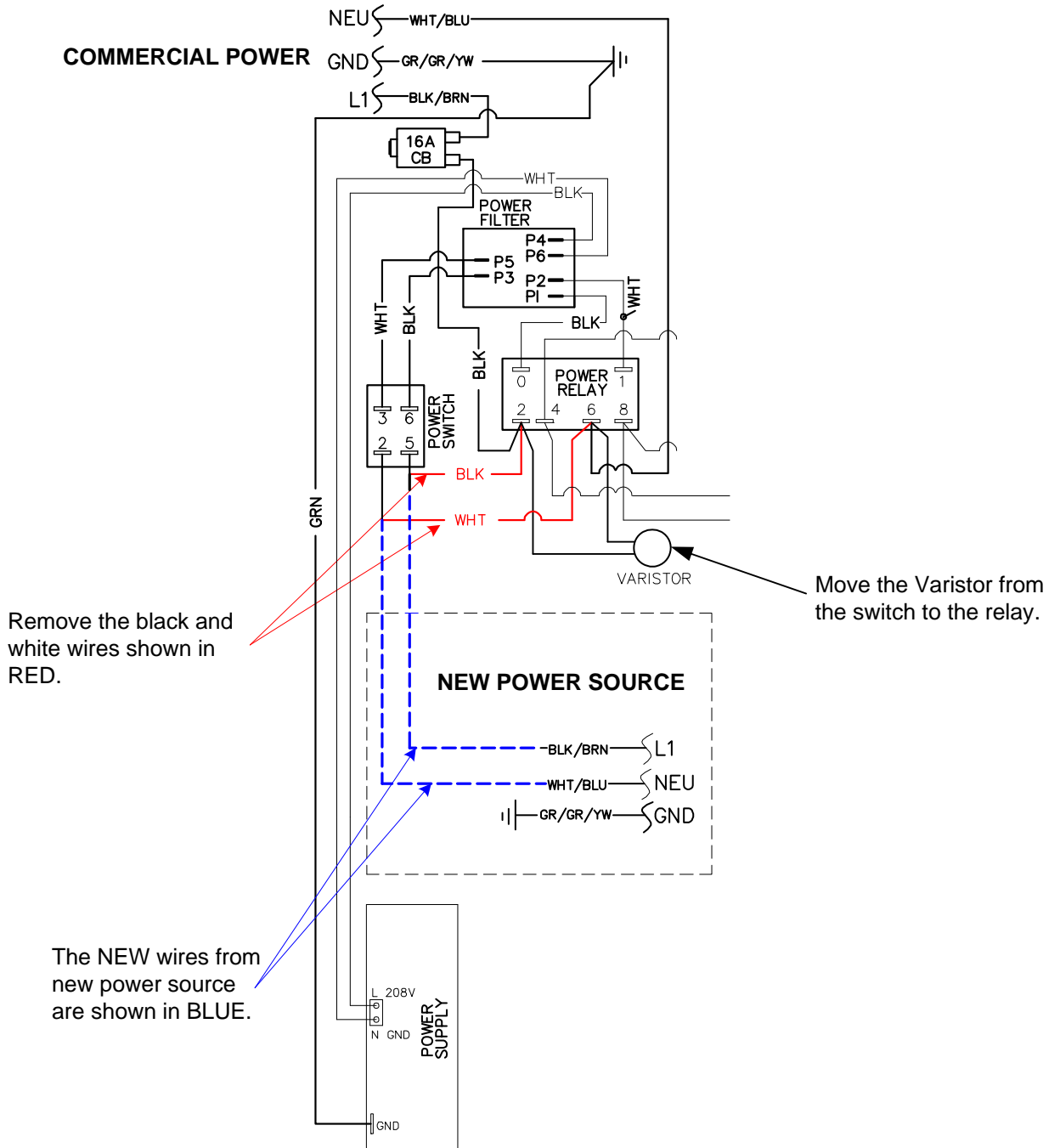

# UHC-P

1. Follow directions on Page 1 to access unit component shelf.
2. Remove wires 4C White and 3C Black (see arrows). The existing power cord and the added wiring are shown below in an inset from the wiring diagram and in the complete diagram.
3. Attach new power cord for external power supply as shown below.

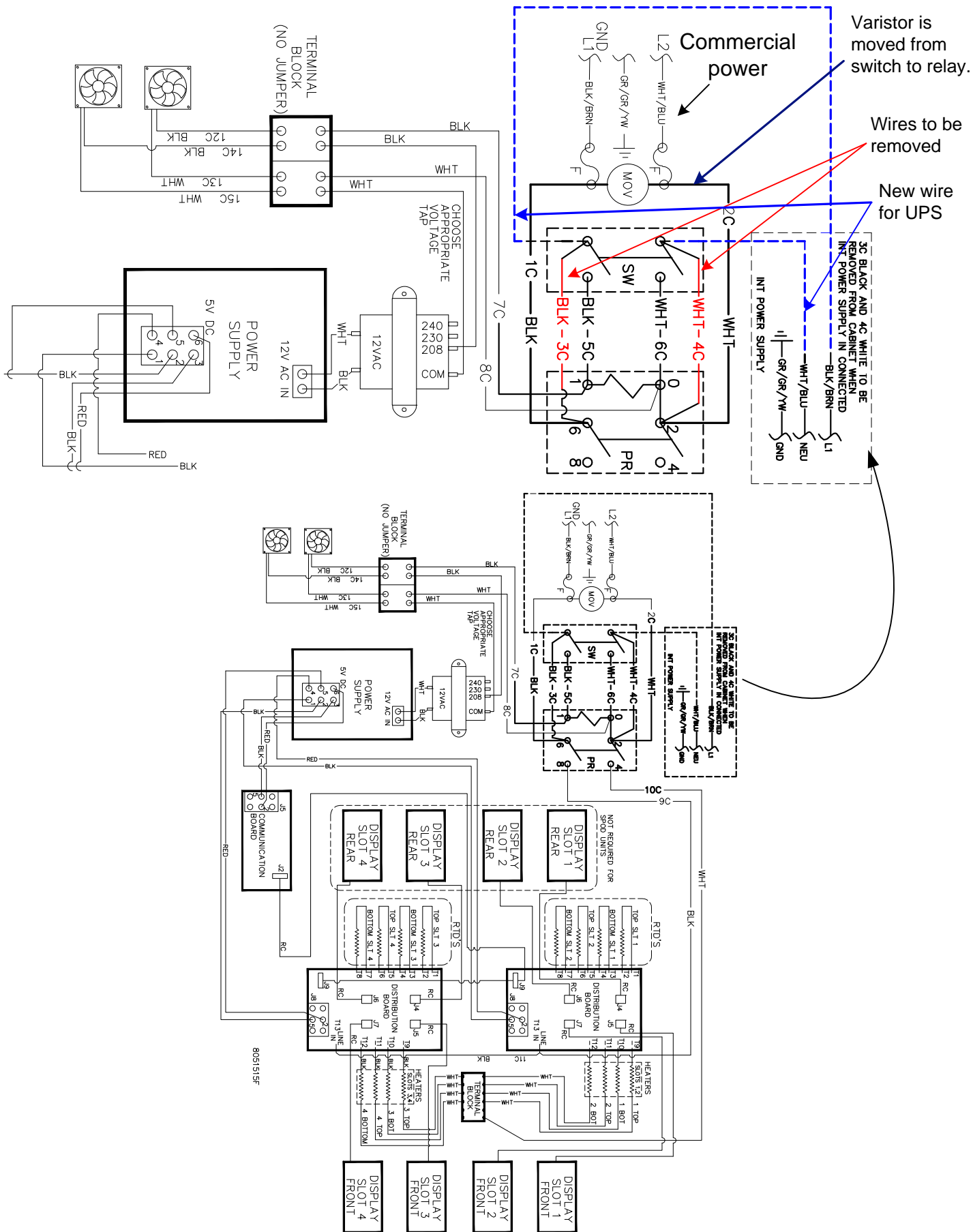

# UHC

1. Follow directions on Page 1 to access unit component shelf.
2. Remove wires 7C Black and 59C White (see arrows). The existing power cord and the added wiring are shown below in the inset from the wiring diagram and in the complete diagram.
3. Replace wire 1C with W1C601 and replace wire 63C with W63C517.
3. Attach new power cord for external power supply as shown below.

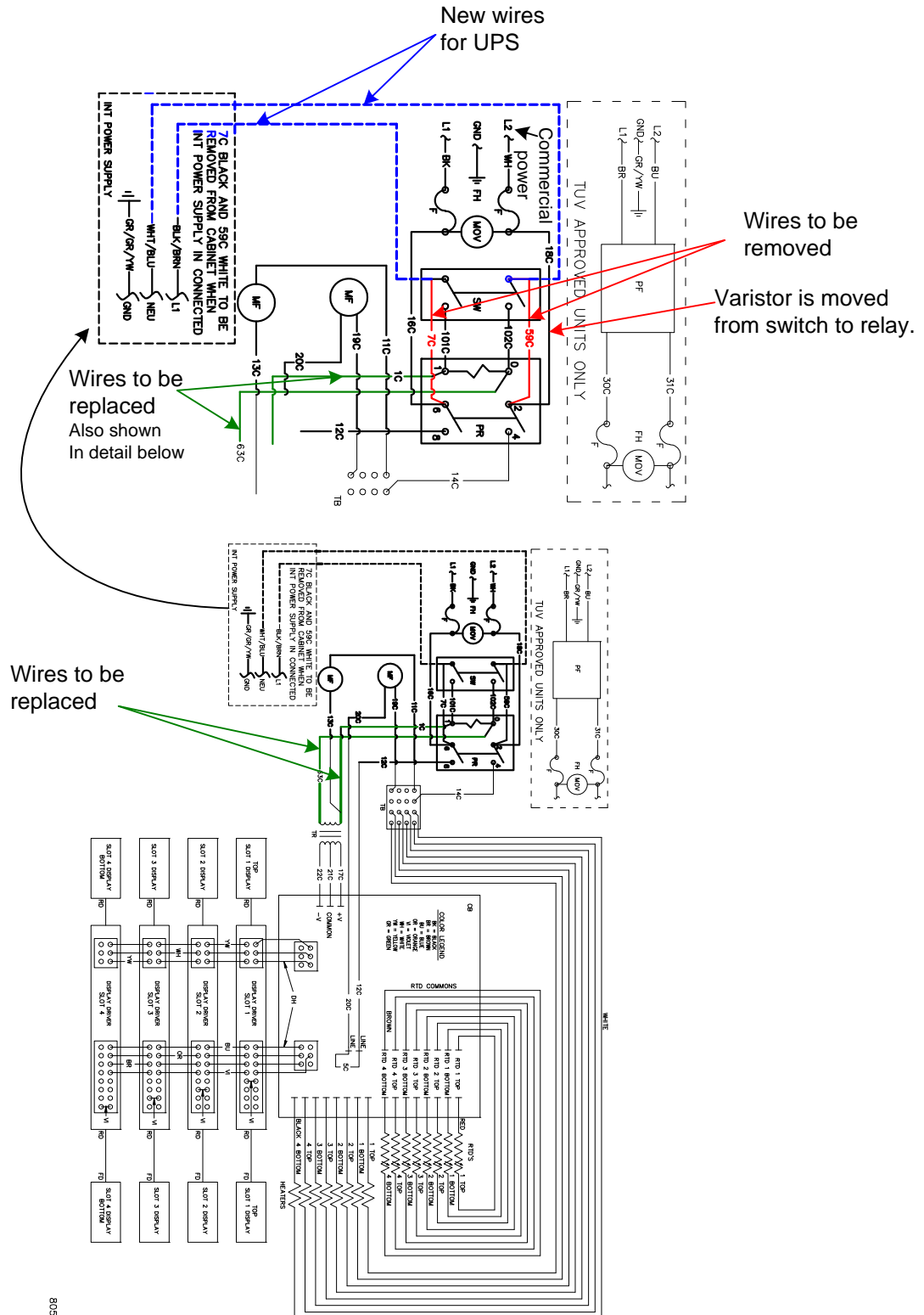

8051342C